

Particular Specification for Non-percussion Cast In-situ Concrete Piles

1.0 Definitions

1.1 Non-percussion cast in-situ concrete piles are piles with diameters not exceeding 610 mm and are either:

- a) Pakt-in Place (PIP) or piles formed by similar techniques, or
- b) piles formed by boring with an auger and temporary casing

1.2 For the purpose of this Particular Specification (PS) the following definitions apply:

Incremental grout factor for 1.5 m increment - Actual grout volume placed divided by theoretical grout volume for the 1.5 m increment.

Total grout factor - Actual grout volume placed divided by theoretical grout volume of pile.

Grout-return depth - The grout-return depth is defined as the depth of the auger tip when the grout on the auger flights reaches the ground surface.

Auger refusal - Auger refusal is defined as a rate of auger penetration of less than 300 mm per minute of drilling.

2.0 Piling Installation Procedures / Details

2.1 General

Non-percussion cast in-situ concrete piles shall be formed by one of the methods described in Clause 2.2 to Clause 2.3 below.

Ground settlement monitoring shall be carried out during pile installation. Should there be any noticeable damage or undue settlement caused by the piling activities, the works shall be stopped immediately and the SO shall be informed accordingly.

A minimum period of 7 days has to elapse following the completion of casting before carrying out pile head cut off work.

The pile may be designed to resist lateral loads.

2.2 Pakt-in Place (PIP)

2.2.1 System Description

The excavation for PIP piles shall be formed by rotating a continuous-flight, hollow-shaft auger into the ground to the designed depth. The flights of the auger are filled with soil as the auger is installed into the ground, and the soil on the auger is used to provide lateral support to maintain the stability of the hole. After reaching the design pile depth, cement sand grout of 25 MPa strength at 28 days shall then be injected with sufficient pressure through the auger shaft, as the auger is being withdrawn, in such a way as to exert an upward pressure as well as a positive lateral pressure on the surrounding soil. The grout shall contain approved admixtures to improve the workability and compensate for the shrinkage effect.

A reinforcement cage, as detailed in Annex 1, shall be lowered into the pile shaft while the grout is still fluid. The reinforcement cage shall be maintained in its final position until the grout has hardened.

2.2.2 Equipment

2.2.2.1 Augering Equipment

The augering equipment shall have adequate torque and down force to turn and advance the augers of specified diameter to the designed depth and maintain adequate penetration speed.

The auger flight shall be continuous from the auger top to the tip without gaps or other breaks. The auger flight shall be uniform in diameter throughout its length and shall be of the diameter specified for the piles less a maximum of 3 percent. The auger cutting teeth shall be regularly inspected for wear and shall be replaced if the above specified reduction in diameter tolerance occurs.

Leads shall be marked at 0.5 m intervals numbered at least every 2 m to facilitate measurement of auger penetration.

2.2.2.2 Mixing and Pumping Equipment

The mixing and pumping equipment to be used in the preparation and handling of the grout have to be assessed and approved by the SO before use. A screen to remove oversize particles shall be placed at the pump hopper or inlet.

The grout pump shall be provided with an operable pressure gauge and stroke counter in clear view of the equipment operator. The grout pump shall be calibrated at the beginning of the work to determine the volume

of grout pumped per stroke, and shall be periodically re-calibrated when deemed necessary by the SO during the project construction. As a minimum, the grout pump shall be re-calibrated (i) after any significant pump maintenance/repair, or (ii) if any modifications to the pump are made, or (iii) if pumps are changed. An approved method of counting grout pump strokes shall be provided by the Contractor. Such methods may include digital or mechanical stroke counters or other acceptable methods.

The grout pump shall be calibrated by using a 250-litre drum. During the calibration, the Contractor must not over fill the 250-litre drum and the site staff must correct the grout volume for the portion of the drum not filled with grout when computing the pump calibration factor. If the grout is provided by a ready mix supplier, additional periodic large-scale calibration checks can be made by dividing the volume of a truckload by the number of strokes pumped to empty it.

2.2.3 Quality Control of Grout

2.2.3.1 Fluidity

Fluidity shall be checked for sample from each truckload of grout using a flow cone in accordance with ASTM C 939. A 19 mm diameter flowcone shall be used. Flow rates shall be within the range of 10 to 25 seconds. The sample for performing the fluidity check should be obtained from the ready mix truck chute.

2.2.3.2 Grout Cubes

Two grout cubes of 100 mm size shall be made for each pile for unconfined compression testing. Additional sets of cubes should be made on any batch of grout used in piles, which appears to deviate from project criteria including placement beyond time limit. The grout sample used to make the compressive testing specimens should be representative of the material in the pile and may be obtained from the grout pump hopper at the time of pumping, the auger or the pile itself.

2.2.3.3 Grout Temperature

Maximum grout temperature shall not exceed 38°C.

2.2.3.4 Initial Set

The Contractor shall sample each truckload of grout directly from the pump hopper using a 225 to 350 mL capacity disposable glass or cup when the grout truck reaches the site to evaluate premature setting or

“initial set” of the grout mix. The grout shall not be used if the initial set has occurred and it is considered that this has occurred when the grout begins assuming the shape of the container when tilted from the vertical.

2.2.4 Installation Procedures

- 2.2.4.1** Advance the auger at a continuous rate that prevents removal of excess soil which can result in reduction of horizontal effective stress and relative density in the soil around the pile being installed and previously installed piles nearby, lateral movement of soil towards the hole, and ground subsidence at the surface. Stop advancement after reaching the required embedment depth.
- 2.2.4.2** Prior to raising the auger, a minimum theoretical initial grout head of 2 m shall be pumped. The grout quantity shall be determined by counting pump strokes and using the pre-determined grout volume per pump stroke. Positive (clockwise) rotation of the auger shall be maintained at all times during placement of the grout. The rate of grout injection and auger withdrawal shall be coordinated so as to maintain:
- (i) Sufficient grout head at all times.
 - (ii) The grout factor for each 1.5 m increment, which shall be not less than the smallest 1.5 m incremental grout factor obtained during the trial pile installation and in no case less than 1.15.
 - (iii) The grout-return depth, which shall be equal to or greater than the grout head that was pumped at the bottom of the pile and shall be at least 2.0 m.
 - (iv) The total grout factor, which shall be not less than the value established during trial pile installation and in no case less than 1.4.
- 2.2.4.3** If grout pumping is interrupted for any reason, or discontinued grout or slurry return at the ground surface is observed, the Contractor shall lower the auger at least 1.5 m below the level where the interruption occurred while continuously pumping grout.
- 2.2.4.4** If the volume of grout placed in any 1.5 m increment result in the incremental grout factor less than the minimum value observed in the trial pile installation, the auger shall be lowered 1.5 m or to the bottom of the pile if that is less, followed by controlled auger withdrawal while maintaining grout injection.

- 2.2.4.5** Auger turning and hoisting equipment shall be provided that will enable the auger to be continuously rotated in a positive (clockwise) direction while being withdrawn at a steady, continuous rate while pumping grout.
- 2.2.4.6** The grout shall be cast at least 600 mm above the specified cut-off level.
- 2.2.4.7** The excess spoil that accumulates around the auger due to the drilling process and grout injection shall be promptly cleared away.
- 2.2.4.8** Reinforcement cage shall be installed immediately upon completion of the grouting operation and before the grout reaches its initial set. The reinforcement cage shall be free of soil, auger spoil or other deleterious materials prior to insertion into the grouted shafts. The reinforcement cage shall fall freely under its own weight to the specified level within the shaft; vibration or pushing of the cage with equipment shall not be allowed.
- 2.2.4.9** Adjacent piles closer than 6 pile diameters shall not be placed within 24 hours of each other.

2.2.5 Non-Conformity

For piles not conforming to any specified requirements (e.g. grout-return depth and/or total grout factor), the Contractor shall lower the auger to the bottom of the pile while the grout is still fluid and regrout the hole. Otherwise, the Contractor shall demonstrate to the SO that the piles in doubt can sustain the design loading. All tests for this purpose shall be at the Contractor's own expense and no extension of time shall be granted whatsoever.

2.2.6 Obstructions

If underground obstruction is encountered in the top few metres of the ground, it can generally be removed and the pile reinstalled at its planned location. For obstruction encountered at greater depths which causes auger refusal, the following procedures should be followed:

- (i) For a pile closer than 6 pile diameters from any completed pile – to grout the hole above the obstruction in accordance with this PS and relocate the pile.
- (ii) For a pile with distance greater than 6 pile diameters from any completed pile – to remove the obstruction by a method approved by the SO, backfill the hole with sand before reconstruction of the pile. However, in the estimation of pile length, the positive shaft friction

contributing to the pile resistance above the obstruction shall be ignored.

2.2.7 Trial Pile Installation

At the commencement of pile installation, at least two trial piles of different lengths shall be installed. The lengths of these two trial piles shall be calculated using equation 1 of Section 3.1, based on two μ values proposed by the Contractor which shall not be greater than 1.6. The Contractor should choose the μ values based on his own capability and equipment to be used in pile installation. These trial piles shall be load tested to Clause 5.28 of the General Specification for Building (GS) to validate the design and method of construction and to determine an appropriate μ value for the design of piles for the Contract.

During the trial pile installation, the total grout factor and the grout factor for each 1.5 m increment of the trial piles shall be recorded. All working piles shall be designed and constructed based on the performance of the trial piles passing the static loading test.

2.2.8 Singlehole Sonic Logging

For each PIP pile, install a single u-PVC access pipe with an internal diameter of 40 mm attaching to the centre of reinforcing steel cage. The length of access pipe should be equal to that of the reinforcing steel cage and filled with water. Sonic logging should be performed about 3 days after the pile has been installed.

2.2.9 Pile Integrity Test

Notwithstanding Annex F of Section 5 of the GS, Pile Integrity Test using Pulse Echo Method/Transient Response Method (Vibration Test) shall be carried out for 15% of the number of PIP piles installed.

2.3 Piles formed by boring with an auger and temporary casing

2.3.1 System Description

These piles are formed by augering with a temporary casing used to stabilise the surrounding soil. The pile shaft shall be filled with concrete of Grade 25 or higher. The maximum aggregate size for the concrete shall be 10 mm. The casing shall be withdrawn slowly while maintaining a sufficient head of concrete in the pile shaft to prevent the caving in of surrounding soil. The actual volume of concrete cast shall be compared with the theoretical volume

and any anomaly observed shall be reported to the SO. The concrete shall be cast at least 600 mm above the specified cut-off level.

The reinforcement cage shall be lowered at a suitable time and maintained in its final position until the concrete has hardened.

2.3.2 Obstructions

When underground obstruction is encountered during pile installation, an auger-drill bit equipped with special tungsten-carbide cutters or other approved equipment may be used to drill through the obstruction.

Down-the-hole hammer may also be used to overcome underground obstruction subject to the agreement of the SO. Do not use down-the-hole hammer to overcome obstruction within 3 m radius of any newly cast pile until a minimum period of 48 hours has elapsed following the completion of casting of any such pile.

2.3.3 Trial Pile Installation

At the commencement of pile installation, at least two trial piles of different lengths shall be installed. The lengths of these two trial piles shall be calculated using equation 1 of Section 3.1, based on two μ values proposed by the Contractor which shall not be greater than 0.7. The Contractor should choose the μ values based on his own capability and equipment to be used in pile installation. These trial piles shall be load tested to Clause 5.28 of the GS to validate the design and method of construction and to determine an appropriate μ value for the design of piles for the Contract.

2.3.4 Pile Integrity Test

Notwithstanding Annex F of Section 5 of the GS, Pile Integrity Test using Pulse Echo Method/Transient Response Method (Vibration Test) shall be carried out for 15% of the number of piles installed.

3.0 Design Requirements

3.1 Design Assumptions

The theoretical safe loading capacity of individual pile shall be the sum of allowable skin friction capacity of the pile (q_s) and the allowable end bearing capacity of the pile (q_a):

$$\begin{aligned} \text{Theoretical safe loading capacity of pile} &= q_s + q_a \\ &= \mu N_{av} P L + 5 N A \end{aligned} \quad (1)$$

Where :

- μ = designed friction coefficient to be verified by trial pile ≤ 1.6 for PIP piles and ≤ 0.7 for piles formed by boring with an auger and temporary casing
- N_{av} = average SPT "N" value along the pile shaft in blows/300 mm (maximum value to be used is limited to 40)
- P = perimeter of pile
- L = length of pile
- A = cross sectional area of pile
- N = SPT value in blows / 300 mm at the pile toe (maximum "N" value to be used is limited to 200)

Note: Shaft friction in filling materials and marine deposits shall be ignored.

It should be noted that the methods of calculating the theoretical safe loading capacity are intended as guidance for general cases. The Contractor shall build in a greater margin of safety in his design where necessary, having regard to the subsoil conditions of the site and his method of pile installation.

3.2 Founding Level

Before commencement of pile installation, additional drill holes shall be carried out to obtain sufficient information for determination of pile length. The additional drill holes shall be in sufficient number such that any pile tip shall not be more than 5m away from the nearest drill hole. This predrilling shall be carried out by an independent Ground Investigation Contractor. Submit two copies of the drill-hole logs to the SO within 3 days of the predrilling.

3.3 Pile Load Capacity

The theoretical safe loading capacity of an individual pile is not to exceed the following:

Load Condition	Capacity of 450 mm diameter pile (KN)	Capacity of 550 mm diameter pile (KN)	Capacity of 610 mm diameter pile (KN)
Dead load + Live load	795	1188	1460
Dead load + Live load + Wind load	994	1485	1825

3.4 Reinforcement Details

Provide reinforcement as shown in Annex 1. Steel reinforcement shall comply with Section 6 of the GS.

- (i) For axially loaded piles, the reinforcement shall be 10 m long or otherwise approved by the SO. .
- (ii) For piles subjected to vertical and lateral loads, the reinforcement should be sufficient to resist all actions including the bending moment. Minimum cover to reinforcement shall be 75 mm.

4.0 Static Loading Tests

Loading tests shall be instructed by the SO in accordance with Clause 5.28 of the GS.

5.0 Piling Records

The Contractor shall keep records of the installation of each pile and submit two signed copies of these records to the SO not later than noon of the next working day after the pile was installed.

5.1 The following aspects of PIP Piles installation shall be documented on each pile installation record in an approved format:

- a) Weather conditions and temperature
- b) Date piles placed
- c) Pile site supervisory staff's name
- d) Grout truck number, arrival time on-site, batch time and batch volume
- e) Grout sampling time and time of initial set
- f) Grout cubes made by the Contractor
- g) Flow cone test results
- h) Auger diameter (note actual diameter each time measured in field)
- i) Time period for drilling of pile
- j) Rate of penetration of auger (Revolution per Auger Pitch)
- k) Abnormal drilling behaviour
- l) Pile drilled length/pile tip and top elevation
- m) Theoretical pile volume
- n) Time period for grouting of pile
- o) Range in pressure observed during grouting
- p) Grout return depth
- q) Grout volume pumped per 1.5 m increment of pile length
- r) Total number of pump strokes to complete pile (actual grout volume)
- s) Total grout factor
- t) Reinforcing steel cage installed in the pile
- u) Special remarks (e.g., time of and reason for interruptions during grouting, extra grout cubes made, etc.).
- v) Any other data requested by the SO.

5.2 The following aspects of piles formed by augering with a temporary casing shall be documented on each pile installation record in an approved format:

- a) Pile type and size.
- b) Pile reference number.
- c) Date and time of boring
- d) Soil samples taken and insitu test carried out if any
- e) Date of concreting.
- f) Position of pile in the works and ground level at pile position.
- g) Working level.
- h) Depth from working level to pile toe.
- i) Depth from working level to pile head level.
- j) Toe level.
- k) Drilling rates and material encountered.
- l) Concrete mix.
- m) Volume of concrete in pile (actual and theoretical).
- n) Details of obstructions, delays and other interruptions to sequence of work.
- o) Any other data requested by the SO.

On completion of all piling, submit to the SO two copies of record piling plan showing, as appropriate, the position, identity number, size and top and bottom levels of each pile installed.

6.0 Design Submissions

In addition to those stated in Clause 5.02 of the GS, submit 2 copies of each of the following with the design submissions:-

- a) Details of concrete / grout / mortar mix.
- b) Method of installation including equipment to be used, sequence of operations, drilling methods.
- c) Pile head, reinforcement details.
- d) Ground settlement monitoring proposal.
- e) Any other requirements specified in this particular specification.

No piling works shall commence on site unless the design submissions are approved by the SO.

ANNEX 1

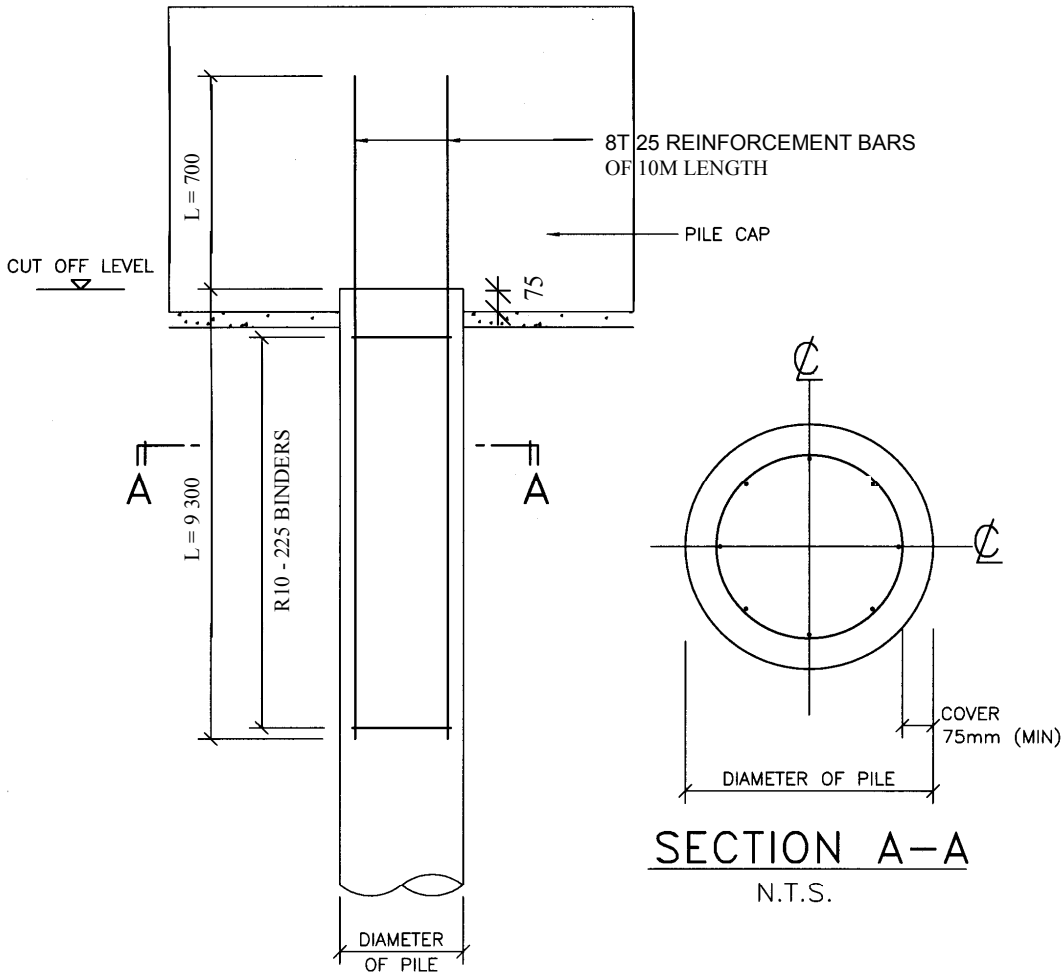

TYPICAL REINFORCEMENT
DETAIL FOR NON-PERCUSSION
CAST IN-SITU CONCRETE PILE

N.T.S.